

LED ILLUMINATED ALUMINIUM CABINETS

Installation Instructions

Carrera

ELECTRICAL SAFETY INSTRUCTIONS

All connections must be installed by a licensed electrician, in accordance with current building codes. Consult a qualified electrician.

IMPORTANT

Always switch off the electrical supply at the main during installation and maintenance. It is recommended that the circuit breaker is switched off for the necessary circuit before installation commences.

Fitting in Bathrooms is subject to the appropriate building code Regulations. This product is NOT suitable for outside zones. It is also Not suitable for installation in saunas, steam rooms or shower cubicles. This product is only suitable for permanent installation. **DO NOT** connect to a trailing plug and socket outlet. This product is only suitable for indoor use. Do not attach the product to surfaces that are damp or otherwise electrically conductive.

INSTALLATION CARE & SAFETY

Wear suitable eye protection when drilling. Take care when using power tools. Beware of hidden cables or pipes. Take care if drilling on tiled surfaces in case the drill slips. A piece of masking tape applied to the wall before marking out the fixing holes will stop the drill from wandering.

IMPORTANT

The product must be installed with a minimum distance of 6" between the infrared sensor and an adjacent wall or obstruction to ensure correct function of the sensor.

(See diagram A)

DO NOT strike glass components with hard or pointed items. **DO NOT** place very hot or very cold items against or in close proximity to glass surfaces unless an adequately thick insulation material is used to prevent such items coming in contact with the glass. The nominal thickness of the mirror glass used in this product is 1/4" and is film backed for safety. If the glass becomes chipped or broken replace immediately.

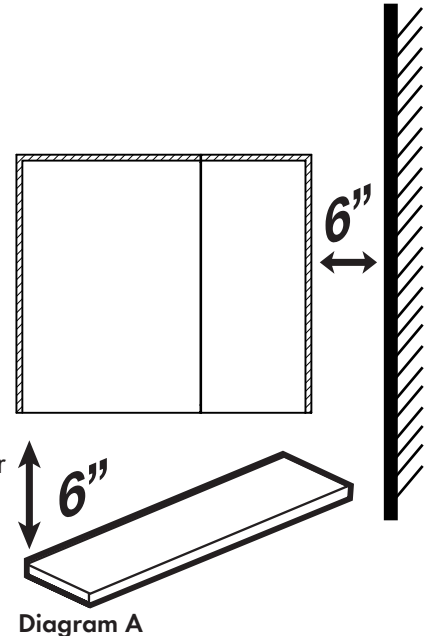

Diagram A

CLEANING

It is recommended that the unit is cleaned with a soft, dry, non abrasive cloth when turned off. Never use cleaning agents or abrasive materials on any type of surface finish. Do not allow moisture to come into contact with the electrical components.



LTL HOME PRODUCTS, INC.

125 Rt. 61 Schuylkill Haven, PA 17972
1-800-360-1585 • fax 570-385-5475 • info@ltlhomeproducts.com
www.ltlhomeproducts.com

LED ILLUMINATED ALUMINIUM CABINETS

Installation Instructions

Carrera

1. Remove the packaging taking special care with the doors and separate shelves. Open the cabinet doors and remove the screws on the doors. Take care not to lose the screws.

2. Using a level, mark off a horizontal line approximately $2\frac{3}{4}$ " below where the top of the cabinet is to be. Position the bracket hole so that they are centred on the line, and ensure that the ends of the brackets are spaced to the width between the inner edges of the vertical aluminium extrusions (see illustration 1). Mark off the holes using a pencil.

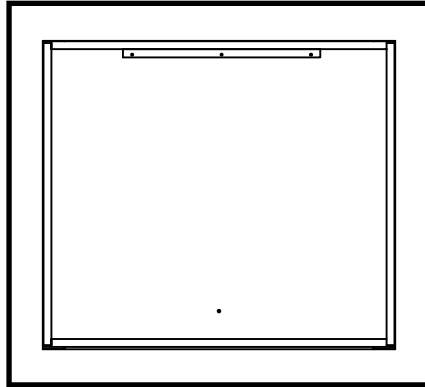
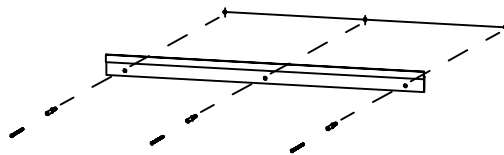

Illustration 1

3. Note: Screws supplied are only suitable for stud walls. For drywall walls use special wall fasteners, available from DIY or hardware stores. Seek advice from a specialist about the suitability of screws to be used. Drill the required holes and insert wall screws.

4. Screw the bracket to the wall using the screws provided. Please ensure the screws are fully tight but take care not to overtighten.



5. Before making any electrical connections it is necessary to turn off the main electricity supply. This unit is provided with a supply cable already fitted. This cable should be fitted to the household lighting circuit or to a fused 3 AMP supply. Connections should be made in accordance with the latest regulations. This cabinet is manufactured to CLASS 1 and requires an earth connection.

6. When the cabinet is fully secure the internal top cover should be closed and secured with the small screws removed earlier. When the cover is closed and secure restore the main power and test the function of the lights and the shaver socket. If the light fails to function properly it is likely the IR sensor has been positioned too close to an adjacent wall or reflective surface

7. Fitting the glass shelves. Firstly insert a shelf into the top two shelf support brackets then slide upwards so the grub screws on the underside of the support brackets (Screw C) can be sufficiently tightened to hold glass in place. Repeat for the bottom shelf (NOTE: be careful not to overtighten). Shelves can be positioned accordingly by sliding the supports up or down (NOTE: Take care to use both hands when sliding shelves and ensure that support brackets at both ends slide simultaneously). Once shelves are in their desired locations turn screw D to secure in position. A level should be used to ensure shelves are level.

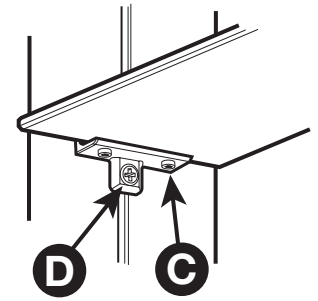

9. If the doors are out of alignment first remove the soft-close buffer (from the relevant hinges) which clips into the main hinge plate. The soft-close hinges offer adjustment in 3 directions via adjustment screws E, F and G (see diagram).

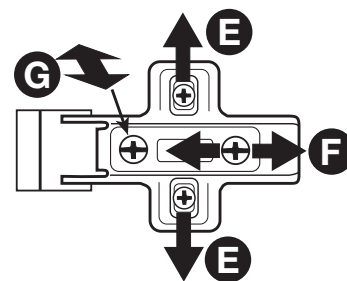
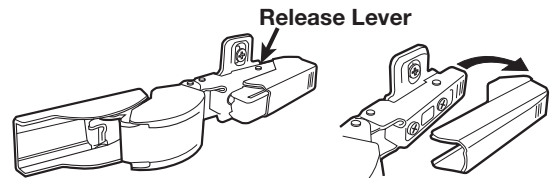

LTL HOME PRODUCTS, INC.

125 Rt. 61 Schuylkill Haven, PA 17972

1-800-360-1585 • fax 570-385-5475 • info@ltlhomeproducts.com

www.ltlhomeproducts.com

LED ILLUMINATED ALUMINIUM CABINETS

Installation Instructions

Carrera

Pairing *Bluetooth*[®] enabled devices:

Pairing occurs when two *Bluetooth*[®] wireless technology enabled devices communicate with each other and establish a connection. This information is then stored in the memory of each device meaning that once initially connected, the two devices will not need to pair again.

Your Mirror can link with up to seven separate devices. When this limit is reached any additional devices paired will erase previous connections to accommodate the new pairing.

Connecting your *Bluetooth*[®] enabled device to your Cabinet:

1. It is recommended that the *Bluetooth*[®] connectivity of the device you want to pair with your Cabinet is turned on first to make connection easier.

2. The *Bluetooth*[®] device will be turned on by using the rocker switch inside the Cabinet

3. On the selected *Bluetooth*[®] enabled device select 'Bluetooth' from the *Bluetooth*[®] device list to connect to the mirror.

Note: Devices running *Bluetooth*[®] Version 2.0 or earlier may need to enter a pairing code before a connection is made. This code is a device default of 0000 or 1234. These devices will not need to enter a pairing code again after the initial set-up. Some devices may also ask for the connection to be accepted, which will be prompted on the device screen.

4. Once connected, any music played on the paired device will play through the Cabinet.

The *Bluetooth*[®] connection will automatically cease when the two paired devices are out of range.

To turn off the Bluetooth[®] functionality simply turn off the rocker switch on the inside of the cabinet on the left hand side.



LTL HOME PRODUCTS, INC.

125 Rt. 61 Schuylkill Haven, PA 17972

1-800-360-1585 • fax 570-385-5475 • info@ltlhomeproducts.com

www.ltlhomeproducts.com

LED ILLUMINATED ALUMINIUM CABINETS

Installation Instructions

Carrera

There is no sound from my Cabinet

- The volume on your device is muted or turned down.
- There is a problem with the *Bluetooth*® connection - try erasing the connection on the audio device and then re-pairing.
- There may be interference from other nearby *Bluetooth*® enabled devices - try turning them off.
- The connected devices are too far apart and out of range - try moving the devices closer together.

I cannot pair the Cabinet with my Bluetooth® device

- The cabinet may not be in pairing mode – to do this turn the rocker switch on located on the underside of the cabinet. The indicator light located on the inside lower right hand side will flash quickly to confirm pairing mode.
- The *Bluetooth*® capability of your chosen device is turned off or out of range.
- There was a problem during pairing - some devices will pair automatically when selected some will require a pass code or acceptance of the connection before they will finalise the pairing.
- Refer to your *Bluetooth*® device's instruction manual to ensure it supports the A2DP (stereo *Bluetooth*®) profile.
- If attempting to connect to a PC or Mac computer, ensure that your cabinet is set as the audio output device within the audio settings menu of the device. You may need to play a track to finalise the connection.

The sound quality is poor

- Your *Bluetooth*® device may be close to being out of range and should be moved closer to the cabinet.
- For those devices that support the use of Applications, there may be too many running in the background which can affect the amount of internal resources available on the device to transmit audio. Closing any non-essential applications may improve audio quality.
- Similarly, if the selected device has Wi-Fi capabilities, turning this off may improve audio quality.
- There could have been a problem during the initial pairing of devices. Erase the connection using your *Bluetooth*® device and re-pair.
- For those devices with in-built sound equalisation, adjusting these settings can greatly improve the sound quality of any audio played through your cabinet.

My Cabinet is not automatically reconnecting with my Bluetooth® device

- The Cabinet will automatically reconnect with paired devices when both devices *Bluetooth*® capabilities are turned on. Depending on the manufacturer of the *Bluetooth*® device, the order in which the devices are turned on to automatically connect may vary. In some cases it will be necessary to turn on *Bluetooth*® capabilities on the audio device before turning on the cabinet.

I turned the Bluetooth® on-off-on and now I can't pair my device

When the *Bluetooth*® module is turned off it enters a shutdown procedure that takes between 10-30 seconds, if this sequence is interrupted by turning the module back on during this shutdown process a software conflict may occur. During a software conflict the *Bluetooth*® module will become unresponsive. To reboot the module turn off the *Bluetooth*® module using the rocker switch and allow to stand for 10 minutes. Normal functionality will resume after this time. To avoid software conflicts always leave 10-30 seconds between turning the *Bluetooth*® module off and back on again.



LTL HOME PRODUCTS, INC.

125 Rt. 61 Schuylkill Haven, PA 17972

1-800-360-1585 • fax 570-385-5475 • info@ltlhomeproducts.com

www.ltlhomeproducts.com